



J1850 VPW (Class 2) FIBER-OPTIC BRIDGE

USER MANUAL

Version 1.2

© 2007 Dearborn Group Inc.
27007 Hills Tech Court
Farmington Hills, MI 48331
Phone: (248) 488-2080, FAX: (248) 488-2082
<http://www.dgtech.com>

This document is copyrighted by the Dearborn Group Inc. Permission is granted to copy any or all portions of this manual, provided that such copies are for use with the product provided by the Dearborn Group, and that the name “Dearborn Group Inc.” remains on all copies as on the original.

IMPORTANT NOTICE

It is essential that you read this document carefully before using the Fiber-Optic products. Damage caused by misuse of this product is not covered by the seller’s product warranty.

When using this manual, please remember the following:

- This manual may be changed, in whole or in part, without notice.
- Dearborn Group Inc. assumes no responsibility for any damage resulting from any accident – or for any other reason – while the Fiber-Optic products are in use.
- Specifications presented herein are for illustration purposes only and do not necessarily represent the latest revisions of hardware. Dearborn Group Inc. assumes no responsibility for any intellectual property claims that may result from use of this material.
- No license is granted – by implication or otherwise – for any patents or any other rights of Dearborn Group Inc., or of any third party.

DG[®] is a registered trademark of Dearborn Group Inc.

GRYPHON[®] is a registered trademark of Dearborn Group Inc.

Other products that may be referenced in this manual are trademarks of their respective manufacturers.

Table of Contents

1	PRODUCT OVERVIEW / GETTING STARTED	4
1.1	Fiber-Optic Bridge functions	4
1.2	Typical usage of a Fiber-Optic Bridge	5
1.3	Package contents	6
1.4	Technical support	6
1.5	Related documents	6
2	FIBER-OPTIC BRIDGE ADAPTER	7
2.1	Power switch	7
2.2	Power jack	7
2.3	DB 9 connector	8
2.4	Fiber-Optical connectors	8
3	FIBER-OPTIC SATELLITE MODULE	9
3.1	Power Switch.....	9
3.1.1	<i>Power to Satellite Module</i>	<i>9</i>
3.1.2	<i>Battery compartment.....</i>	<i>9</i>
3.2	DB 15 Connector	10
3.3	Fiber-Optic connectors	11
3.3.1	<i>Fiber-Optic and Copper wire connections from the CLASS 2 Bridge to the DUT ...</i>	<i>11</i>
3.3.2	<i>Fiber-Optic connections</i>	<i>11</i>
3.4	Power On and Battery Low indicators for Satellite Module.....	12
3.4.1	<i>Power On status LED</i>	<i>12</i>
3.4.2	<i>Battery Low status LED</i>	<i>12</i>

1 Product Overview / Getting Started

Dearborn Group supports several interfaces for use in an EMC test environment. These products, using fiber-optic cabling, provide vehicle network connectivity to device(s) under test (DUT).

1.1 Fiber-Optic Bridge functions

The Fiber-Optic Bridge consists of two major components: The Fiber-Optic Bridge Adapter and the Fiber-Optic Satellite Module.

The Bridge Adapter works as a pass-through hardware device. It translates the vehicle network electrical signals from the *GRYPHON*[®] tool (or a user's host test device) into fiber-optic signals. These fiber-optic signals are used to interface with the Satellite Module placed in the EMC Test Chamber. The fiber-optic signals are then translated back into vehicle network electrical signals by the Satellite Module and used to communicate with the DUT.

Hardware features of the Satellite Module

- Anodized aluminum enclosure
- Anteroom with feed through capacitors
- SMA Fiber-Optic connectors
- Powered via two internal nine-volt batteries
- Low battery status indicator

Hardware dimensions of the Satellite Module

<i>Housing:</i>	Height:	1"
	Width:	6"
	Depth:	2.3"

Note: Above dimensions do not include clearance for toggle switch and connectors.

1.2 Typical usage of a Fiber-Optic Bridge

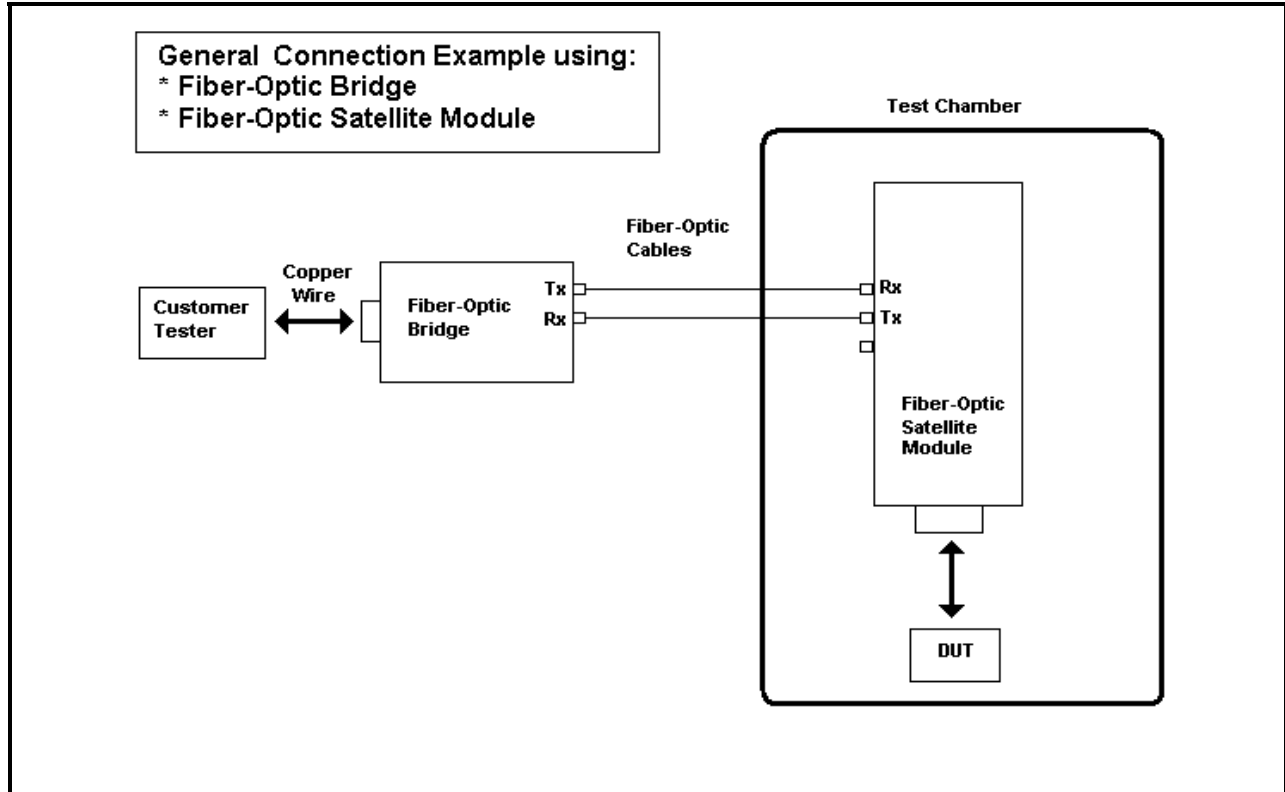

Figure 1: Typical Setup for a Fiber-Optic Bridge

1.3 Package contents

The Fiber-Optic Satellite Module package should include the following items:

- Class 2 Fiber-Optic Bridge, including a 12 VDC Universal A/C power adapter
- Class 2 Fiber-Optic Satellite Module (nine-volt batteries not included)
- Two fiber-optic cables with SMA connectors (10 meters in length)
- CD with the user Manual for the Fiber-Optic Bridge

If you discover that you are missing any part of this package, please contact your Dearborn Group sales representative or the technical support hotline at once.

1.4 Technical support

In the U.S., technical support representatives are available to answer your questions between 9 a.m. and 5 p.m. EST. You may also fax or e-mail your questions to us. Please include your voice telephone number, for prompt assistance.

Phone: (248) 488-2080
Fax: (248) 488-2082
E-mail: techsupp@dgtech.com
Web site: <http://www.dgtech.com>

1.5 Related documents

Document
<i>SAE HS 3000 Handbook (On-board Diagnostics)</i>

IMPORTANT!
Please read the following before using the fiber-optic module.

2 Fiber-Optic Bridge Adapter

Figure 2 that follows depicts the label of the J1850 (Class 2) Fiber-Optic Bridge Adapter.



Figure 2: Label for the Class 2 Fiber-Optic Bridge Adapter

IMPORTANT NOTE: When connecting the fiber-optic cables, always connect Cable 1 from the Bridge to **Rx** (Cable 1) on the Satellite, and Cable 2 from the Bridge to **Tx** (Cable 2) on the Satellite. (Please see Figure 3 on page 9 for a view of the label for the Satellite Module.)

2.1 Power switch

This switch is used to apply/disconnect power to the Class 2 Fiber-Optic Bridge. Power to the unit is applied when the switch is placed in the “up” position.

2.2 Power jack

This standard 2.5 mm x 5.5 mm connector (with positive center pin) is used to provide power to the J1850 (Class 2) Fiber-Optic Bridge. This power jack is designed to accept an input range between 8 to 18 VDC. The typical operating voltage supplied by the included Universal Power Adapter is approximately 12 VDC.

2.3 DB 9 connector

This connector is used to connect the host controller to the Class 2 Fiber-Optic Bridge.

Table 1 below provides the pin out assignments for the DB 9 (male) connector on the Class 2 Bridge Adapter that connects to the host test device.

Note: Make only the two connections indicated in Table 1 below.

Class 2 Protocol Bridge Adapter DB 9 Connector (male)		
Pin Number	Function	Remarks
3	J1850 VPW (Class 2) Bus	Connect to Class 2 Bus of Host
5	Ground	Connect to Ground of Host
All other pins	N/A	Make no connection to these pins.

Table 1: Pin Assignments for Class 2 Bridge Adapter for connections to Host

2.4 Fiber-Optical connectors

These two connectors are used to connect the Class 2 Fiber-Optic Bridge to the Class 2 Fiber-Optic Satellite Module, using the supplied 10-meter length fiber-optic cables.

Note: To ensure reliable data transmission, the length of each cable used should not exceed 100 meters.

IMPORTANT

When connecting the cables between the Bridge Adapter and Satellite Module, always connect Cable 1 from the Bridge to **Rx** (Cable 1) on the Satellite Module, and Cable 2 from the Bridge to **Tx** (Cable 2) on the Satellite Module. (See Figures 2 and 3 for a view of the labels for the respective units.)

3 Fiber-Optic Satellite Module

The Class 2 Fiber-Optic Satellite Module is normally placed inside of the test chamber, although it is often used for tests performed outside the chamber as well. Figure 3 that follows depicts the label for the Class 2 Fiber-Optic Satellite Module.

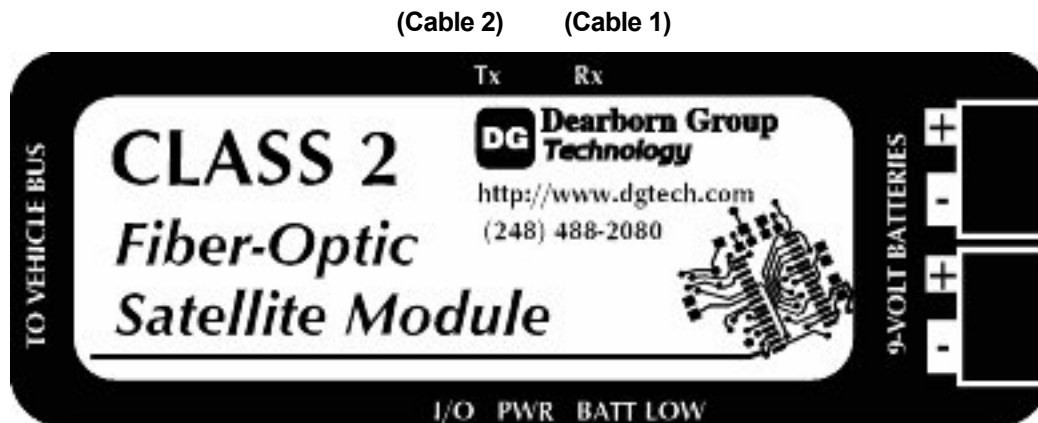

Figure 3: Class 2 Fiber-Optic Satellite Module

3.1 Power Switch

This switch (marked **I/O PWR** on the label above it) is used to turn power on or off to the Class 2 Satellite Module. Power is applied when the switch is moved to the left (I).

3.1.1 Power to Satellite Module

Power is supplied to the Satellite Module via two internal nine-volt batteries and is controlled by the toggle switch (see Section 3.1 above).

3.1.2 Battery compartment

Two nine-volt batteries inserted into the battery compartment supply power to the unit and are connected as indicated on the Satellite Module label (see Figure 3 above).

3.2 DB 15 Connector

This connector is used to connect the Class 2 Fiber-Optic Satellite Module to the DUT (Device Under Test).

Table 2 that follows provides the DB 15 (HD female) connector pin out assignments used to connect the Satellite Module to the DUT.

ATTENTION!
The DUT can NOT be powered from the Class 2 Satellite Module.

Note: Only the two connections shown in Table 2 below are to be made between the Satellite Module and the DUT.

Caution: Making a connection to any of the other pins of the DB 15 connector could result in damage to the equipment.

Class 2 Protocol Satellite Module DB 15 Connector (high density female)		
Pin Number	Function	Remarks
2	Class 2 Bus	Connect to Class 2 Bus of DUT
5	Ground	Connect to Ground of DUT
All other pins	N/A	Make no connection to these pins.

Table 2: Class 2 Satellite Module Pin Assignments for Connections to DUT

CAUTION!
Make only the connections to the DB 15 and DB 9 connectors as indicated in Tables 1 and 2 above. Other pins contain signals and voltages and any connection made to them could cause damage to the hardware.

3.3 Fiber-Optic connectors

These SMA connectors are used to connect the Class 2 Fiber-Optic Satellite Module to the Class 2 Fiber-Optic Bridge, using the supplied optic cables (each 10 meters in length).

NOTE: To ensure reliable data transmission, the length of each fiber-optic cable used should not exceed 100 meters.

3.3.1 Fiber-Optic and Copper wire connections from the Class 2 Bridge to the DUT

See the following Table 3 for the fiber-optic connections between the Bridge Adapter and the Satellite Module and for the copper wire connections between the Satellite Module and the DUT.

Fiber-Optic Cables Connect Bridge To Satellite	DB15 (copper wires) Satellite Connector To DUT
Cable 1 to Rx (Cable 1)	Pin 2 to Class 2 Bus
Cable 2 to Tx (Cable 2)	Pin 5 to Ground

Table 3 Fiber-Optic and Copper Connections to Satellite Module

3.3.2 Fiber-Optic connections

The fiber-optic cable needed for connecting the units is a 100/140 Micro multimode fiber-optic cable with SMA connectors. Please see Figure 2, Figure 3 and Table 3 as a reference for connecting the fiber-optic cables.

3.4 Power On and Battery Low indicators for Satellite Module

3.4.1 Power On status LED

This red status LED (closest to the power switch) will be turned on when battery power is switched on. It remains on momentarily and then turns off to conserve battery power.

3.4.2 Battery Low status LED

This status LED (farthest from the power switch) will **NOT** be illuminated during operation **unless** there is a low battery condition, in which case the red LED will be turned on. When this LED is illuminated, it indicates that the enclosed batteries are not providing sufficient power for the proper operation of the module and the batteries should be replaced.

Note: Do not attempt to run further tests until the batteries have been replaced.