

# Gryphon Loop Back Connector Application Note

This document describes how to use the loop back connectors to test the following dual channel Gryphon cards: Dual HS CAN (82527 and SJA1000), Dual SW CAN (82527 and SJA1000), FT CAN -Ver. 1.2 Only, and DLC.

## Using the loop back connector

Typically, you would Telnet into the Gryphon and TX channel one with RX returning into channel two. Confirm that the signal you are transmitting on channel one is being received on channel two.

Next, transmit on channel two. Confirm that the signal that you are transmitting on channel two is being received on channel one. This confirms that the card is fully operational and can transmit and receive signals on each channel.

## Confirming that both channels are set at the same speed

Note that before performing a loop back test on a dual channel card, it is necessary to ensure that both channels have been configured to operate at the same speed. To do this, connect the Gryphon using a web browser:

`http://192.168.1.1` (or the currently assigned address)

Click the “channel/Stats” link in the left hand column. This will display a detailed summary of the installed channels. To change a channel’s speed, click the “Setup” button for that channel. Next, select the appropriate preset from the speed drop-down list (or custom to manually assign a speed instead). Then check the initialize check box and press the “Set” button to apply the changes.

## ESTABLISH A TELNET CONNECTION TO THE GRYPHON

Open the Command Prompt from the following location on your PC:

```
Start > Programs > Accessories > Command Prompt
```

Once opened, establish a telnet connection with the Gryphon by issuing the following command at the command prompt:

```
telnet 192.168.1.1 (or the currently assigned address)
```

Upon connecting successfully, the Gryphon will prompt you for the username and password. The default login information is as follows:

```
Login:    root
Password: dggyrphn
```

It is important to note that on Linux based systems (such as the Gryphon) most data input is case sensitive. Lowercase names and commands must therefore be entered in lowercase.

## USING GRYPHRX

Once logged into the Gryphon, launch the gryphrx program by issuing the following command at the prompt:

```
gryphrx localhost
```

When gryphrx begins, it will first display a list of installed modules and then display any message activity until closed. To close the program press CTRL-C.

Sample initial gryphrx output:

```
Server at localhost: GRYPHON, ver. 20041216, serial 00:90:5A:00:00:1C
Server configuration: 2 devices (*=RCV ON)
```

```
Ch. 1 * Type 02/02. DG-CAN-SJA1000      ver.1.2, Ds=00-08, Es=00-00, Hs= 2 4
Ch. 2 * Type 02/02. DG-CAN-SJA1000      ver.1.2, Ds=00-08, Es=00-00, Hs= 2 4
```

In this case, there is one SJA1000 module installed with two available channels. The Ds, Es, and Hs fields indicate the allowed size in bytes for the message data, extra, and header fields respectively.

**USING GRYPHTX**

Now that gryphrx is monitoring the installed modules, open a second telnet session to the Gryphon using the same method as before. In this session, use the **gryphtx** command to send some test messages.

```
gryphtx -h 07 FF -d FF FF FF FF -c 1
gryphtx -h 07 FF -d 00 00 00 00 -c 2
```

The -h parameter specifies the message header and -d the data bytes. The channel is specified using the -c parameter.

Over in the gryphrx session, some similar output should appear:

```
000001 TX Ch 01:  T: 33292719020 H: 07 FF  D: FF FF FF FF
000002 RX Ch 02:  T: 33292719110 H: 07 FF  D: FF FF FF FF

000003 RX Ch 01:  T: 33297938250 H: 07 FF  D: 00 00 00 00
000004 TX Ch 02:  T: 33297938330 H: 07 FF  D: 00 00 00 00
```

The above indicates that it was successful sending and receiving data on each of the channels.

**Loop Back Connector Pin details for each card type [FT CAN -Ver. 1.2 Only]**

Card Type	Information
Dual HS CAN card (82527 and SJA1000)	The DB-15 HD male with pins 1 and 2 shorted, pins 6 and 7 shorted, and one 120 ohm ¼ W 5% resistor between pins 1 and 6.
Dual SW CAN card (82527 and SJA1000)	The DB-15 HD male with pins 6 and 7 shorted.
FT CAN card (SJA1000FT)	The DB-15 HD male with pins 1 and 2 shorted, pins 6 and 7 shorted, and pins 14 and 15 shorted.
DLC card	The DB-9 male with pins 2 and 3 shorted.

**LOOP BACK ADAPTER WIRING**

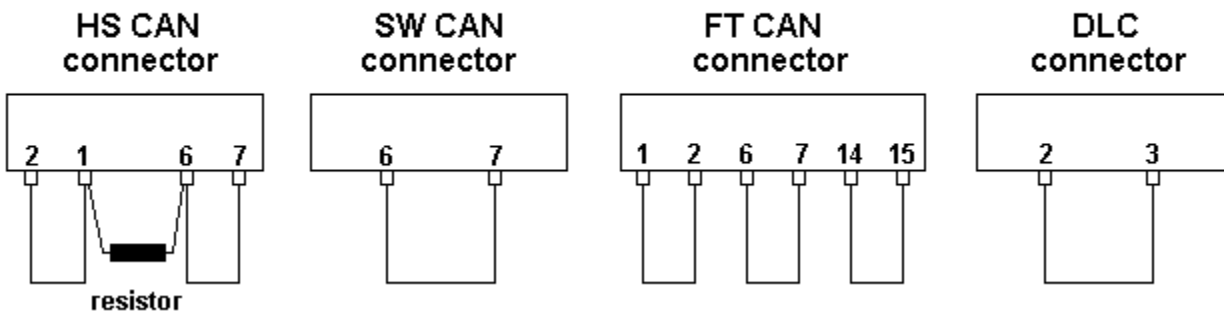

**Loop Back Connector Pin Assignments for each card type [FT CAN -Ver. 1.2 Only]**

<b>Pin</b>	<b>Dual HS CAN card (82527)</b>	<b>Dual HS CAN card (SJA1000)</b>	<b>Dual SW CAN card</b>	<b>FT CAN card (SJA1000FT)</b>	<b>DLC card</b>
1	Channel 2 CAN-Low	Channel 2 CAN-Low		Channel 2 CAN-Low	
2	Channel 1 CAN-Low	Channel 1 CAN-Low		Channel 1 CAN-Low	Channel 1 J1850 Bus
3					Channel 2 J1850 Bus
6	Channel 2 CAN-High	Channel 2 CAN-High	Channel 2 CAN BUS	Channel 2 CAN-High	
7	Channel 1 CAN-High	Channel 2 CAN-High	Channel 1 CAN BUS	Channel 1 CAN-High	
14				VREF+	
15				V+ in	
<b>Note:</b>	A 120 ohm resistor between CAN High and CAN Low is required.	A 120 ohm resistor between CAN High and CAN Low is required.			

03-29-05

<p><b>Dearborn Group, Inc.</b></p> <p>(248) 488-2080      (248) 488-2082      <a href="mailto:dg@dgtech.com">dg@dgtech.com</a></p>		
--	--	--

Copyright © 2005 Dearborn Group, Inc.